



ENGINE MANUAL
Operation / Maintenance / Installation
AE50R
AE50RA
AE50RAB

Doc. No. : E1.01.01 – E
Revision : 6
Date of Revision : 10 March 2011

The technical information contained in this document has been approved under the authority of DOA No. EASA.21J.399 in conjunction with the Mandatory Design Change MDC E1 - 116.

Affected Pages:

Chapter	Page
all	all

Instruction:

- Replace the affected pages of the original manual with the pages contained in this revision.

Austro Engine GmbH
Rudolf - Diesel – Straße 11
A – 2700 Wiener Neustadt
Austria

FOREWORD

We congratulate you on the acquisition of your new Austro Engine AE50R.

Skillful operation of the engine increases both safety and the enjoyment of flying. Please take the time therefore, to familiarize yourself with your new AE50R.

This engine may only be operated in accordance with the procedures and operating limitations of the Engine Manual.

This document is protected by copyright. All associated rights, in particular those of translation, reprinting, radio transmission, reproduction by photo-mechanical or similar means and storing in data processing facilities, in whole or part, are reserved.

Austro Engine is a part of Diamond Aircraft Industries GmbH.

Copyright © by: AUSTRO ENGINE GmbH
 Rudolf-Diesel – Strasse 11
 A – 2700 Wiener Neustadt
 Austria

Phone : +43 – 2622 – 23000
Fax : +43 – 2622 – 23000 - 2711
E-Mail : office@austroengine.at

1.1 Record of Revisions

All revisions of this manual, with the exception of -

- Temporary Revisions

must be recorded in the following table. Revisions of approved chapters require the countersignature of Austro Control GmbH.

The new or amended text is indicated by a vertical black line at the right hand side of the revised page, with the revision number and data appearing at the bottom of the page.

If pages are revised which contain information valid for your particular serial number (modification level of the engine, Equipment Inventory, etc.), then this information must be transferred to the new pages in hand-writing.

Temporary revisions, if applicable, are inserted behind the cover page of this manual. Temporary revisions are used to provide information on systems or equipment until the next 'permanent' revision of the Engine Manual. When a 'permanent' revision covers a Mandatory or Optional Design Change (MDC or ODC), then the corresponding temporary revision is superseded.

It is the responsibility of the operator to ensure that this manual is maintained to a current status.

If you move, or the ownership of the engine/aircraft changes, please complete the change of address card and send it to Austro Engine GmbH.

Rev. No.	Reason	Chapter	Page(s)	Date of Revision	Approval	Date of Approval	Date In- serted	Signature
1	Editorial changes	5.2.3	5 6	15-02-06	-	-		
		5.2.4	6					
	Part No Correction	11.1	26		-	-		
	Page numbering	all	all					
2	Editorial Changes	1.2	1-4	10-04-06				
		8.1.5	8-1					
		8.5.4	8-3					
		9.4	9-3					
		9.5.	9-4					
		9.5.1						
		9.5.2						
		9.5.3	9-5					
		13.5.5	13-5					
		14.1	14-1					
			14-2					
		18.7.1	18-12					
18.8.1	18-15							
18.8.2	18-16							
	Maintenance Interval	12.1	12-1					
3	New spark plug implemented	1.1	1-3	22-11-06				
		1.2	1-4					
		11.1	11-1					
4	No. changed	1.1	1-3	10-11-08				
		1.2	1-4					
		8.3	8-1					
		11.1	11-1					
5	Editorial change	1.1	1-3					
		1.2	1-4					
		8.3	8-1					
		9.4	9-3					
		11.1	11-1					

6	All Diamond Logos changed to Austro Engine Logo. Oil specification changed	all	all	10-03-11				
---	--	-----	-----	----------	--	--	--	--

1.2 LIST OF EFFECTIVE PAGES

Ch.	Page	Date
1	1-1	10-March-2011
	1-2	10-March-2011
	1-3	10-March-2011
	1-4	10-March-2011
	1-5	10-March-2011
	1-6	10-March-2011
	1-7	10-March-2011
2	2-1	10-March-2011
3	3-1	10-March-2011
	3-2	10-March-2011
4	4-1	10-March-2011
5	5-1	10-March-2011
	5-2	10-March-2011
	5-3	10-March-2011
6	6-1	10-March-2011
	6-2	10-March-2011
	6-3	10-March-2011
7	7-1	10-March-2011
	7-2	10-March-2011
8	8-1	10-March-2011
	8-2	10-March-2011
	8-3	10-March-2011
	8-4	10-March-2011
9	9-1	10-March-2011
	9-2	10-March-2011
	9-3	10-March-2011
	9-4	10-March-2011
	9-5	10-March-2011
10	10-1	10-March-2011
11	11-1	10-March-2011
	11-2	10-March-2011
12	12-1	10-March-2011
	12-2	10-March-2011
	12-3	10-March-2011
13	13-1	10-March-2011
	13-2	10-March-2011
	13-3	10-March-2011
	13-4	10-March-2011
	13-5	10-March-2011
14	14-1	10-March-2011
	14-2	10-March-2011
15	15-1	10-March-2011
	15-2	10-March-2011
16	16-1	10-March-2011

Ch.	Page	Date
17	17-1	10-March-2011
	17-2	10-March-2011
18	18-1	10-March-2011
	18-2	10-March-2011
	18-3	10-March-2011
	18-4	10-March-2011
	18-5	10-March-2011
	18-6	10-March-2011
	18-7	10-March-2011
	18-8	10-March-2011
	18-9	10-March-2011
	18-10	10-March-2011
	18-11	10-March-2011
	18-12	10-March-2011
	18-13	10-March-2011
	18-14	10-March-2011
	18-15	10-March-2011
	18-16	10-March-2011
18-17	10-March-2011	
18-18	10-March-2011	
19	19-1	10-March-2011
	19-2	10-March-2011
	19-3	10-March-2011

1.3 TABLE OF CONTENTS

	Chapter
INTRODUCTION (a non-approved chapter)	1
PREFACE (a non-approved chapter)	2
SAFETY INFORMATION (a non-approved chapter)	3
(RESERVED) (a non-approved chapter)	4
GENERAL ENGINE DATA (a non-approved chapter)	5
OPERATING DATA / LIMITATIONS (an approved chapter)	6
COMPONENTS (a non-approved chapter)	7
DECRPTIONS OF SYSTEMS (a non-approved chapter)	8
OPERATING THE ENGINE (a non-approved chapter)	9
ENGINE EMERGENCY PROCEDURES (a non-approved chapter)	10
MAINTENANCE NOTES (a non-approved chapter)	11
SCHEDULED MAINTENANCE (a non-approved chapter)	12
COOLING SYSTEM (a non-approved chapter)	13

ENGINE INTERNAL INSPECTION (a non-approved chapter)	14
GROUND RUN (a non-approved chapter)	15
MAINTENANCE AND OVERHAUL (a non-approved chapter)	16
TROUBLE SHOOTING (a non-approved chapter)	17
NOTES FOR INSTALLERS OF ENGINES (a non-approved chapter)	18
FORM SHEETS (a non-approved chapter)	19

2.0 PREFACE

Every reasonable effort has been made to ensure that the information contained in this publication is correct when going to print.

However, as Austro Engine GmbH policy is one of continuous improvement, the information given here may be superseded over a period of time by manual revisions or temporary by Service Bulletins.

THIS MANUAL IS PUBLISHED BY:

Austro Engine GmbH

Rudolf – Diesel - Straße 11
A – 2700 Wiener Neustadt

Tel.: +43 (0) 2622 – 23000
Fax.: +43 (0) 2622 – 23000 - 2711
Internet: www.austroengine.at

This manual is for use with engines specified by Engine Type Certificate Data Sheet No
EASA.E.085.

3.0 SAFETY INFORMATION

The instructions in this manual have been compiled to assist pilots and personnel responsible for maintenance in the correct operation of the engines produced by Austro Engine GmbH. Only correct operation and maintenance can ensure optimum availability throughout engine life.

No recommendation in this manual absolves operators from compliance with any official directive that may be issued by the controlling aviation authority of any country concerned, or with any relevant Austro Engine GmbH Service Bulletins.

Austro Engine personnel are always happy to answer queries or give advice on individual service problems. All queries to Austro Engine GmbH should be accompanied by details of the engine model and serial number, hours operated and any other relevant information.

3.1 Safety Symbols

NOTE !

A note symbol shows an additional significant information.

CAUTION!

A caution symbol indicates special procedures which should be followed to avoid the risk of serious damage to engine or to components.

WARNING!

A warning symbol indicates special procedures, which must be followed to avoid the risk of death or serious injury to persons.

3.2 Model Designation Breakdown

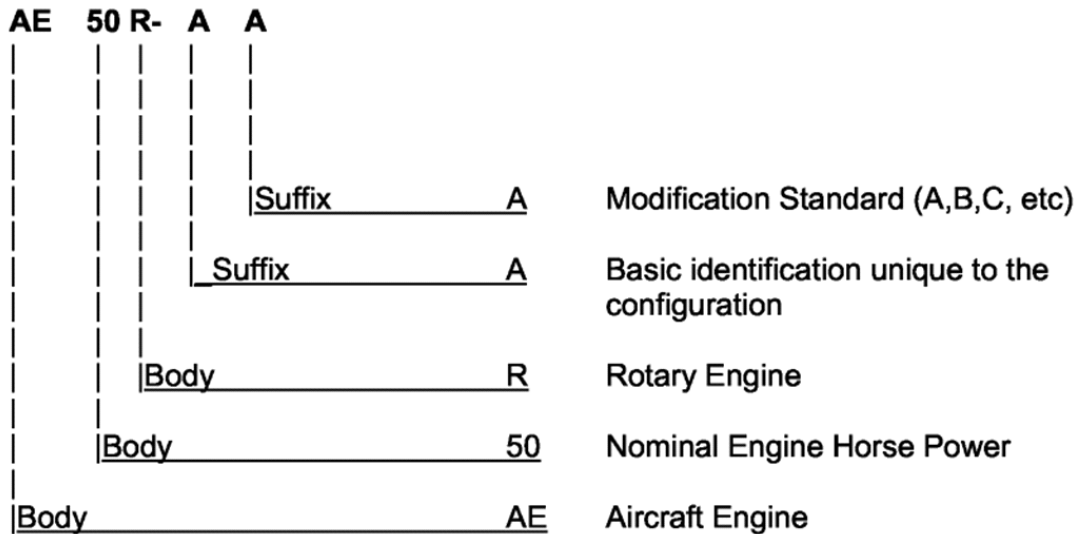

3.3

NOTE!

It is strongly recommended that only genuine, quality-assured, replacement spare parts are used when carrying out maintenance operations on this engine.

The use of parts not approved by Austro Engine GmbH may significantly affect the performance, reliability and life of the engine and may hazard the operator.

WARNING!

The use of parts not approved by Austro Engine GmbH may invalidate the Engine Certification.

4.0 Reserved

Intentionally left blank

5.0 GENERAL ENGINE DATA

5.1 Description

Wankel type rotary, single rotor, dual spark ignition, liquid cooled rotor housing, forced air cooled rotor, normal aspirated.

5.2. Technical data

5.2.1 Design Responsibility

Austro Engine GmbH

Rudolf – Diesel – Straße 11

A – 2700 Wiener Neustadt

Austria

5.2.2 Certification

Certification Basis: JAR – 22, Subpart H, at Change 4 effective 12/12/85 together with Orange Paper amendment 22/01/90.

5.2.3 Engine Particulars

Design	Single rotor Wankel–type rotary engine
Eccentricity	11.6 mm
Width of Housing	68.2 mm
Generating Radius	69.0 mm
Compression Ratio	9 : 1
Swept Volume	294 ccm
Rotor	Cast iron internally cooled by a belt driven centrifugal fan.
Main and End Housing	Aluminium alloy castings, cooled with a pump circulated pressurized water–glycol mixture and supporting an optional oil separator assembly (supplied by the installer mounted directly onto the outlet casting).

Eccentric Shaft

Hardened and ground alloy steel. The complete rotating assembly is in full dynamic balance to minimise vibration, achieved by counter weighting each end of the assembly. Both the main and rotor bearings are rolling element types.

Flywheel

Cast iron fitted with an induction–hardened steel starter ring gear.

5.2.4 Out–put Drive

Take from the eccentric shaft via a woodruff key.

Rotation Direction

The eccentric shaft rotate in a clockwise direction when viewed from the driving side of the engine.

5.2.5 Net Dry Weight

Approximately 26,8 kg. (59,1 lbs)

5.2.6 Cooling

Approximately 90% of surplus heat is rejected into the liquid cooling system; the balance is rejected via rotor cooling air.

Coolant

50 : 50 Distilled Water – Ethylene Glycol mix
Silkolene PRO–COOL (or equivalent)

5.2.7 Fuel Specification

AVGAS 100LL
EUROSUPER, ROZ 95, in accordance with EN228
or equivalents.

5.2.8 Pressure to Carburettor

min 0.276 bar (4 psi)

max 0.414 bar (6 psi)

5.2.9 Lubrication

Lubrication of all bearings and rubbing surfaces is achieved via two lines from the oil metering unit driven off the water pump. The flow rate of the metering unit is calibrated and must not be adjusted. Use only approved engines oils.

Oil Separator

An optional oil separator is recommended. The separator is to be supplied by the engine installer.

5.2.10 Oil Specification

Silkolene Comp 2 Premix (Not comp 2 Injector)

Castrol XR77 (EMPA specification 417478/01)

Castrol Power 1 Racing 2T (API TC+, JASO FD, ISO EGD)

AeroShell Oil Sport Plus2 (API TC)

6.0 OPERATING DATA / LIMITATIONS:

Static sea level ratings under the following conditions:

- International Standard Atmospheric conditions at seal level
- Generator functioning
- Liquid coolant outlet temperature 65 °C (± 5 °C)
- Standard induction pipe fitted with filter
- Power measured at eccentric shaft output
- Approved fuels
- Test bed exhaust used

6.1 Maximum Take – off Rating

Max. T/O – Power (minimum)	36.5. kW (49 BHP) (Value quoted includes losses associated with intake exhaust conditions specified.)
Max. T/O – RPM	7 500 RPM
Fuel consumption (max)	19 - 21 liters / hr
Exhaust back pressure	0.21 bar \pm 0.04 bar (3 psi \pm 0.5 psi) at 7500 RPM with test bed system

6.2 Maximum Continuous Rating

Max. Cont. Power	34.3 kW (46 BHP)
Max. Cont. RPM	6,900 RPM
Fuel consumption (max)	12 - 15 liters / hr

6.2.1 Power Curve

Fig. 1, Typical Power Curve

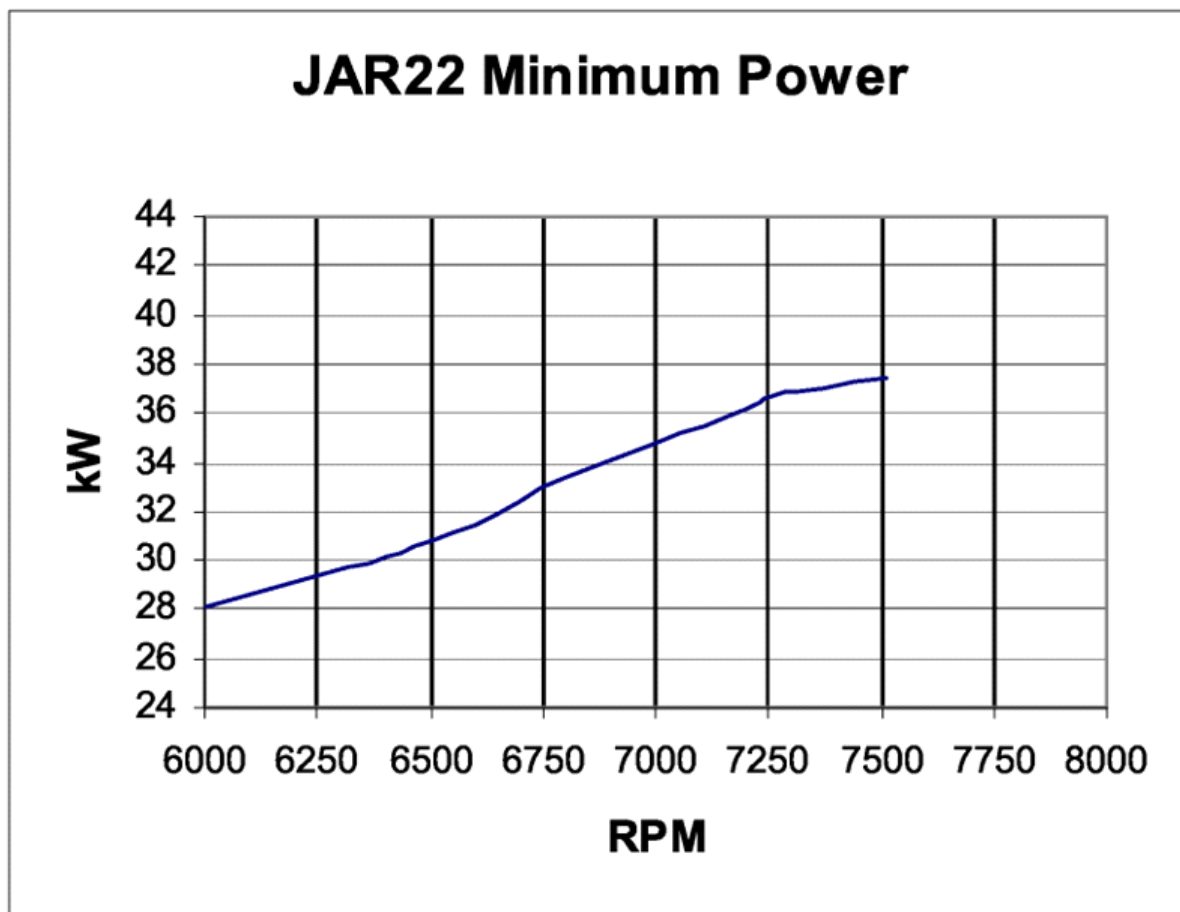

6.3 Operating Limitations

6.3.1 Engine RPM

Maximum for take-off (for 3 mins)	7 500 RPM
Maximum Continuous	6 900 RPM
Maximum Overspeed (20 sec. limit)	7 800 RPM
Idle Minimum	1 750 RPM

6.3.2 Ambient Temperature Limits

Minimum Starting Ambient (without priming)	-10 °C
Maximum Ambient	+55 °C

6.3.3 Liquid Coolant Temperature Limits

Maximum for Take-off	90 °C
Minimum for Take-off	60 °C
Maximum continuous	100 °C

6.3.4 Rotor Cooling Air Outlet Temperature Limits

Maximum for Take-off (3 minutes)	120 °C
Maximum Continuous	110 °C

6.3.5 Exhaust Gas Temperature (EGT)

Maximum Exhaust Gas Temperature	950 °C
---------------------------------	--------

6.3.6 Fuel Pressure

min	0.276 bar (4 psi)
max	0.414 bar (6 psi)

6.3.7 Altitude

The engine has been tested for use up to 14.000 ft pressure altitude

6.4 Manuals

Operation / Maintenance / Installation	Doc. No. E1.01.01-E
Overhaul Manual	Doc. No. E1.04.01-E

7.0 COMPONENTS

Location of Components

FIGS. 2 & 3

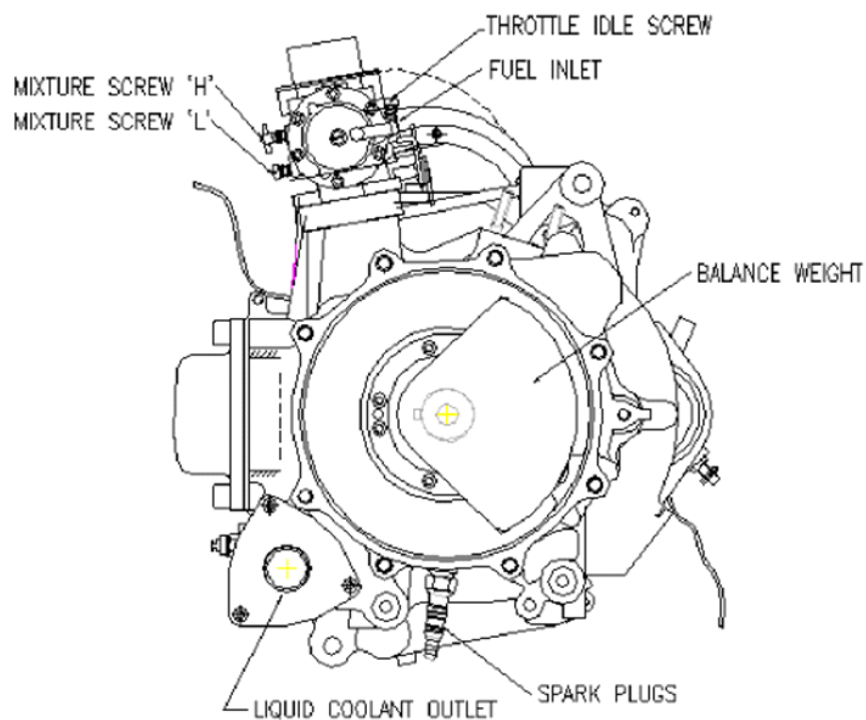
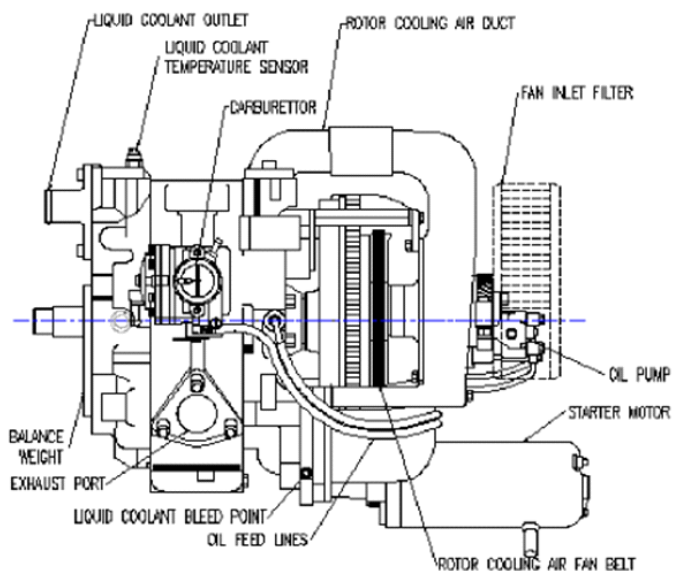

7.1 Description of Components

7.1.1 Rear Assemblies

These assemblies comprise of a back plate, with integral mounting lugs, water pump, alternator, speed sensors, rotor cooling air fan assembly, oil pump and starter motor.

7.1.2 Front Assemblies

The front assemblies comprise of a water cooled end plate, temperature transmitter.

7.1.3 Center and Rotating Assembly

The center assembly comprises a rotor housing with passageways for liquid cooling. Externally is the throttle body with fuel injector, spark plugs, and exhaust flange and, internally, the eccentric shaft and rotor assembly.

7.1.4 Rotor Sealing

Rotor sealing is provided by the tip seals, side seals and corner seals with each seal being spring loaded outwards. The corner seals placed at the junction of the side and tip seals provide sealing at these critical locations.

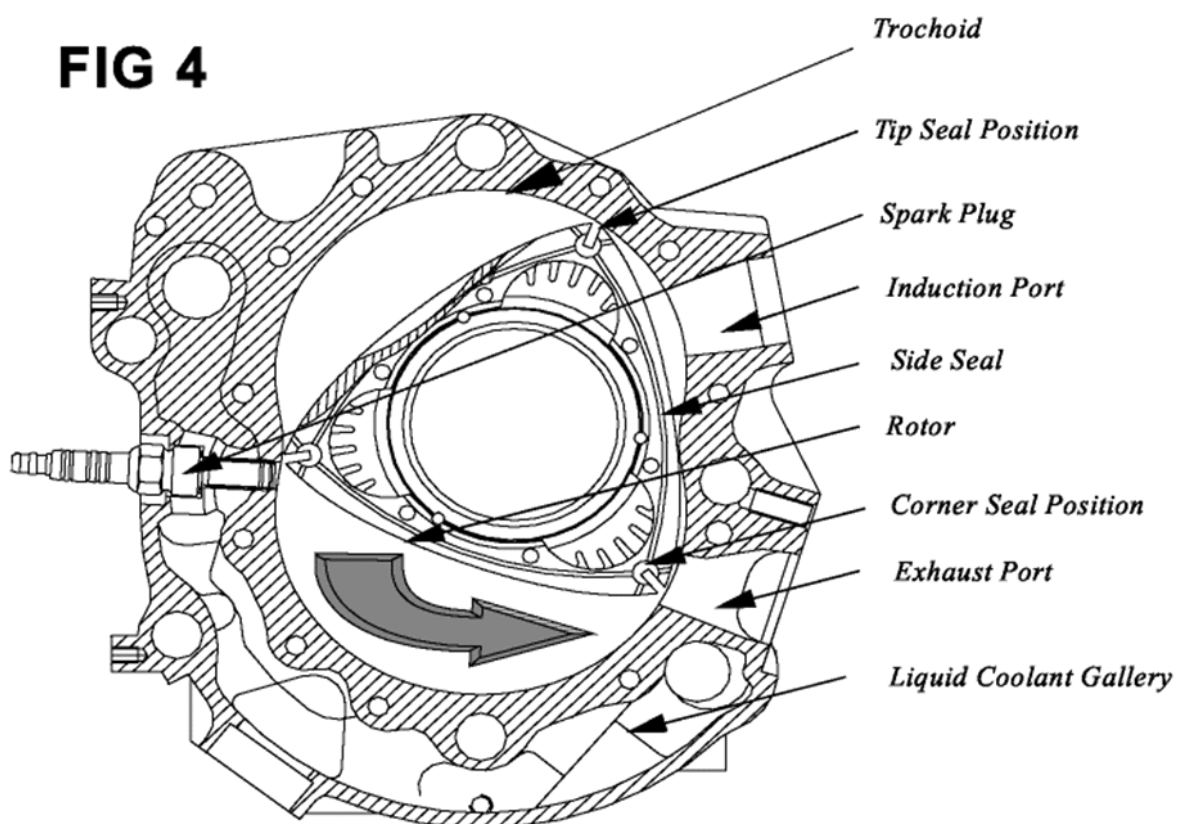

8.0 DESCRIPTOPN OF SYSTEMS

8.1 Ignition System

8.1.1 Supply

The CDI Unit receive their supply via duplicated feeds from the aircraft bus bar (2 x 1 amps circuit breakers).

8.1.2 Triggering

Two steps in the rim of the flywheel, nominally 180° apart, inductive fixed timing sensors.

8.1.3 Ignition

The spark plug pair are fired simultaneously, each by its own coil, triggered by the output from the CDI unit. Each ignition switch interrupts the supply to its coil.

8.1.4 H.T. Leads

The inductive H.T. coils are connected to the spark plugs by copper–cored cable and resistive plug caps.

8.1.5 Spark plugs

The specified spark plug type must be used; substitution with a non–approved type may reduce engine power and reliability, and may cause mechanical damage to the engine.

8.2 Generator System

A flywheel mounted 18 amp brushless / bearing less generator, with a separate voltage control regulator / rectifier unit, provides 14 volt DC supply to the aircraft bus bar.

8.3 Starter

The starter is an electric starter operated with 12 V, 50 A. It is of a Bendix Type, engaging the gear when operated (refer to drawing no. R1A-90-000-000).

8.4 Fuel System

8.4.1 Fuel Pressure

The fuel system requires clean fuel with a minimum fuel flow capability of 45 liters per hour at working pressure.

8.5 Cooling System

8.5.1 Liquid Cooling System

Coolant Circuit Items

FIG 5

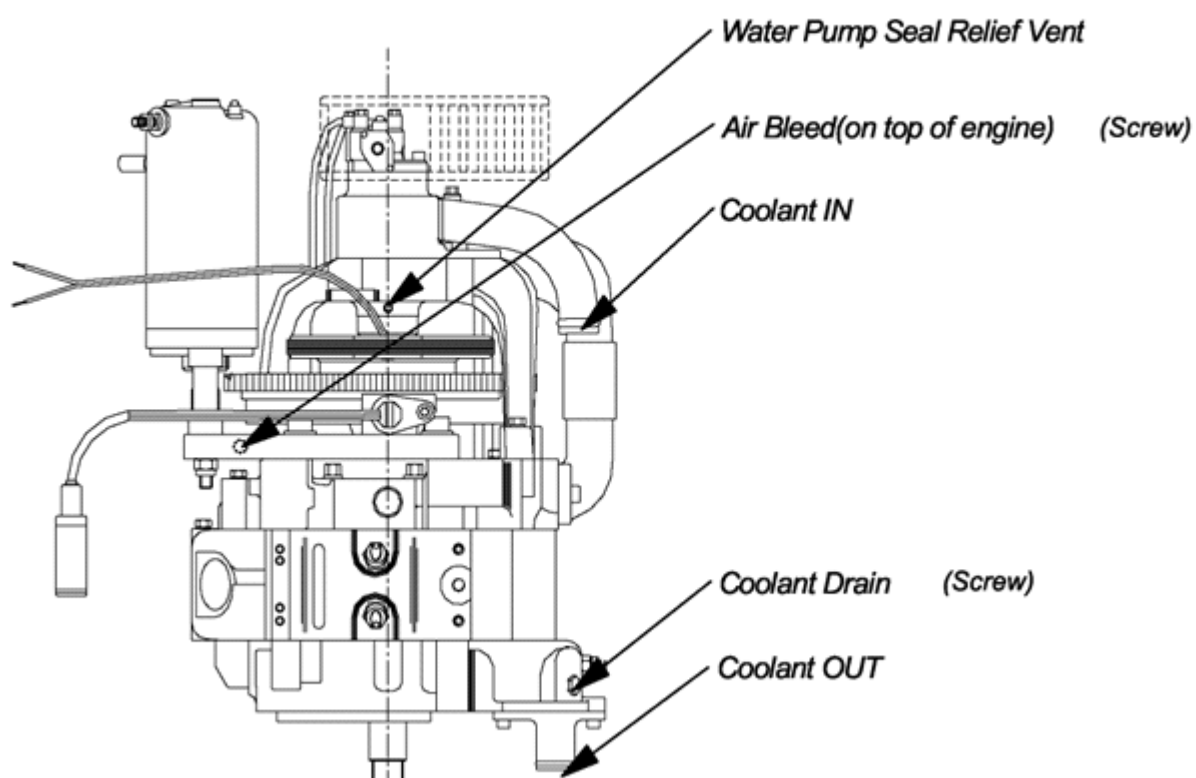

8.5.2 Water Pump

A water pump impeller, driven from the eccentric shaft via a tufnol drive coupling (a shear point) is mounted at the rear of the engine and circulates coolant through the engine casting and radiator.

8.5.3 Temperature Regulation

No thermostat is fitted. A minimum coolant temperature of 60 °C must be maintained and a normal operating temperature of 70 °C is desirable.

8.5.4 Coolant Temperature Sensor

A temperature sensor is fitted to the engine in the front plate, for connecting to a temperature gauge.

8.5.5 Coolant

Coolant is a 50 / 50 water – ethylene glycol mix. For details refer to Chapter 5.2.6

CAUTION !

The use of a pre-mix solution such as Silkolene Pro-Cool is strongly recommended so that there is no variation in the strength or the heat transfer properties of the coolant.

8.5.6 System Pressure

The cooling system is a closed loop system, designed for a working pressure of 0.9 bar (13 psi).

8.5.7 Air cooling system

Lubrication of the eccentric shaft rear bearings is achieved by direct injection of oil from the metering oil unit and results in an oil mist being entrained into the rotor cooling air system. The oil mist, in turn, lubricates the rotor bearing, front main bearing and cools the inside of the rotor.

8.5.8 Rotor Cooling Air Parts

FIG 6

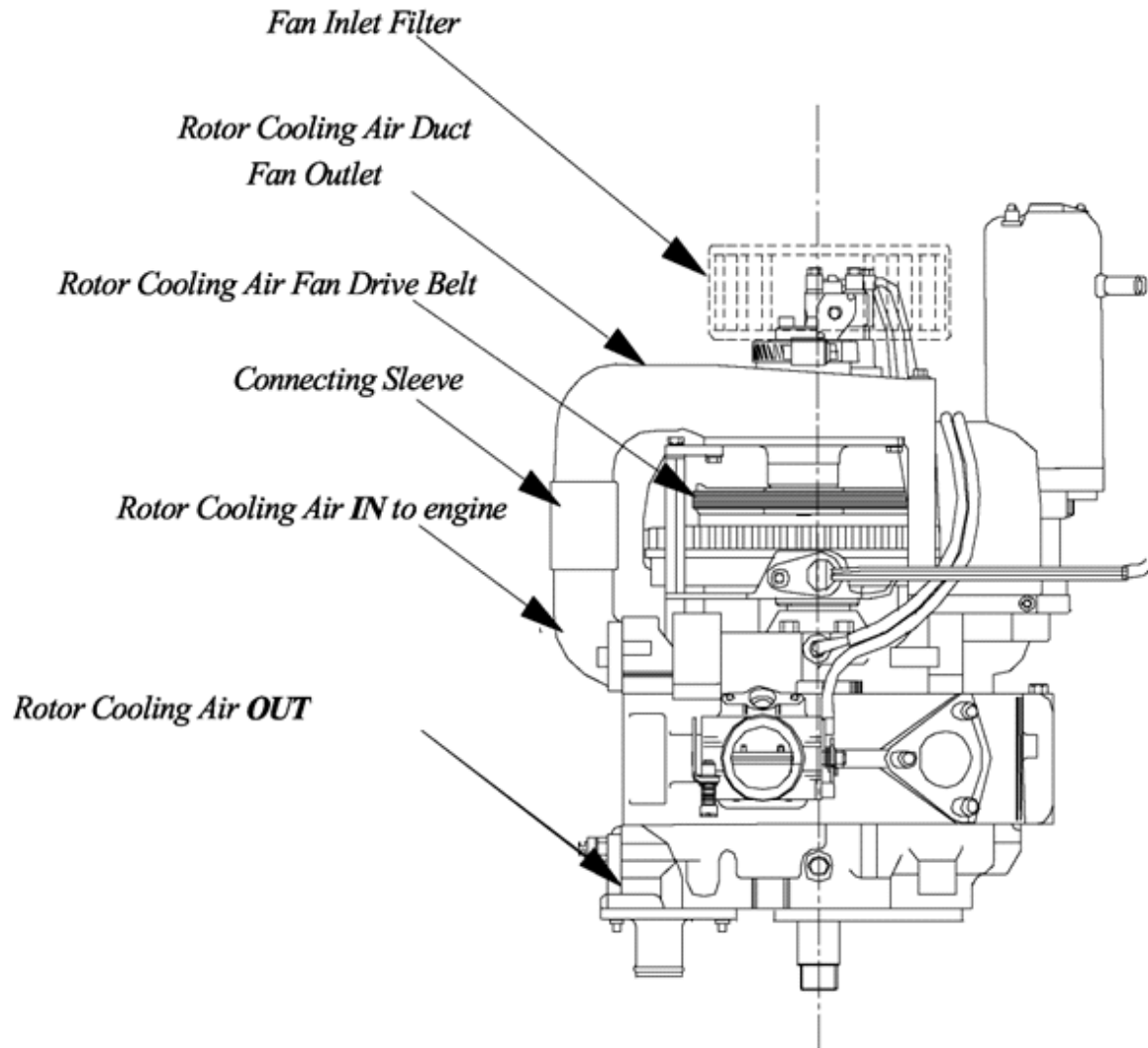

9.0 OPERATING THE ENGINE

9.1 Starting Procedure and Warm-up

Starting

The settings, start and warm-up procedures for the first start of a newly installed engine are obviously to be treated with the greatest care. However, all engines supplied by Austro Engine GmbH will have been fully run-in and performance-tested prior to shipping.

NOTE !

If the engine fails to start after three attempts (normal maximum starter engagement per attempt of five seconds) there is something incorrect! (Fuel, ignition, or outside air temperature). Starting between -5 °C and -10 °C may require assistance for the aircraft battery!

- 1) Check coolant level, that the engine oil tank level is sufficient for flight / test and that the fuel is sufficient, on, and water free.
- 2) Set throttle slightly off the idle stop.
- 3) Switch on battery and alternator.
- 4) Switch on ignition – verify that all gauges / alarms are correct.
- 5) Switch on both fuel pumps – verify that all gauges / alarms are correct.

WARNING !

Ensure all personnel are clear of propeller and aware that the engine is to be started.

- 6) Operate fuel primer to aircraft manufacturers instructions (if installed)
- 9) Crank the engine for 5 seconds (or less if the engine starts).
- 10) If the engine fails to start, recheck switch positions and alarms.
- 11) If cold start – repeat (6 & 7) at 15 second intervals.
- 12) See NOTES above for starting limitations.
- 13) Allow engine to warm up at approximately 3000 RPM to 50°C.
- 14) Check that the rpm rise is smooth and trouble free.
- 15) A sudden liquid coolant temperature rise indicates air trapped in the system. In this case the bleed procedure should be carried out without further running (see 13.3).

CAUTION !

During cold starts not more than 5 x 5 second start attempts in any 3 minute period.

9.2 Engine Start down to Approximately -10 °C

The engine will start equally well with either permitted fuels.

9.3 Ground Tests

(See 15.0)

9.3.1 Full Power Check

Set WOT and note rpm achieved in relation to the minimum acceptable value as defined in the aircraft operating manual. Check that all instrumentation is functioning and that all parameters are within limits. Check that single ignition drops are less than 300 RPM at 6200 RPM.

9.3.2 Idle Check

Fully close the throttle and note rpm; it should be 2300 RPM \pm 100 RPM. Adjustment, if required, is by the throttle stop screw on the throttle body. For method, and precautions, see the aircraft manufacturer's manual.

9.3.3 Stopping the Engine

It is usual to idle the engine for 2 to 3 minutes before stopping (to dissipate internal heat prior to shut down) [see aircraft manufacturers operating manual].

Switching off either the ECU power, or ignition switches, or the fuel pumps will stop the engine. The latter gives a short run down and dissipates pressure in the fuel lines.

9.4 Power Loss at Altitude

Performance at altitude is degraded due to a reduction in air density. The approximate power available (at given RPM / throttle setting) is given in 6.1.1 for Sea Level.

FIG 7

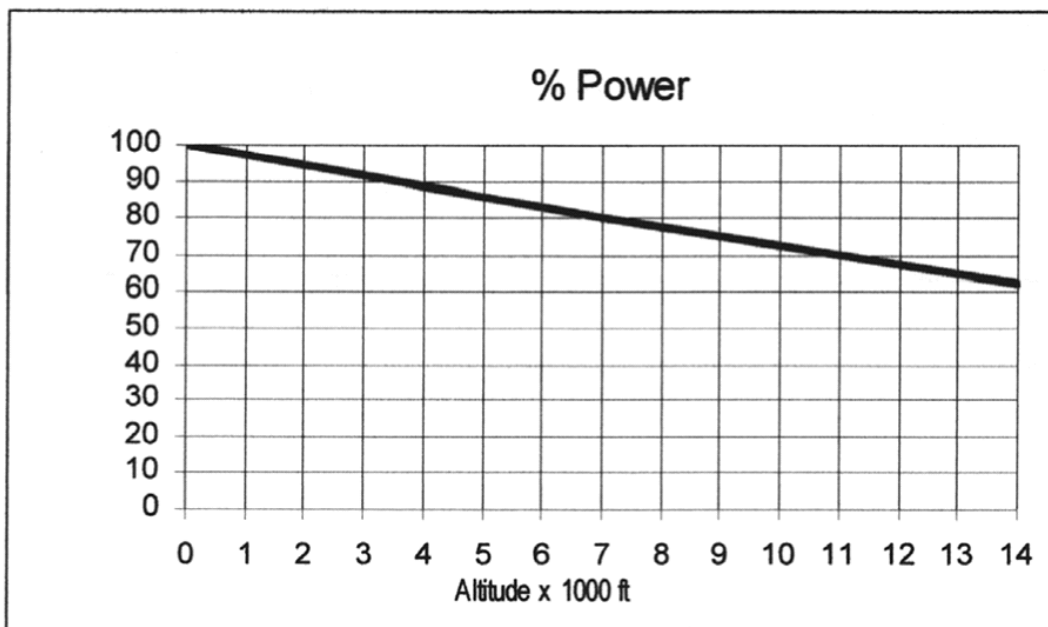

9.5 Storage

General (installed engine).

Proper steps must be taken, on engines used infrequently, to lessen the possibility of corrosion. This is especially true if the aircraft is based near the sea coast or in areas of high humidity.

In all geographical areas the best method of preventing corrosion of internal parts of the engine is to fly the aircraft at least once a week. Alternatively the engine should be run long enough to reach normal operating temperatures.

9.5.1 Storage up to 90 Days

No special treatment is required for storage periods of up to 90 days.

The aircraft should be protected from the weather and excessively damp conditions.

9.5.2 Storage over 90 Days

NOTE !

The following procedures may require that the engine is removed from the aircraft – see aircraft manufacturer's instructions.

CAUTION !

Never rotate the engine with the oil can nozzle still in the spark plug or exhaust / inlet ports!

- 1) To protect the internal of the engine it is recommended that additional engine oil be introduced. This can, for example, be via the spark plug holes, the throttle body or the exhaust and is determined by the aircraft manufacturer.
- 2) Where appropriate, ensure all electrical circuits are off, and then manually rotate the propeller shaft and engine.
- 3) Inject 5cc of the prescribed engine lubrication oil through either spark plug hole in the rotor housing. (See CAUTION! above)
- 4) Rotate the engine through 1/3 revolution of the flywheel (by turning the propeller or propeller shaft and hence the eccentric shaft, by hand).
- 5) Repeat (3 & 4) five times.
- 6) Rotate the engine through 6 revolutions of the flywheel then refit the spark plugs.
- 7) Seal all inlets and exhaust openings to prevent moisture ingress.
- 8) To protect the bearings and associated parts, engine oil should be introduced into the area. The aircraft manufacturer describes the method by which this is achieved and the instructions must be followed carefully.

- 9) Blank off all open holes.
- 10) To protect the outside of the engine, anti corrosion oils of well-known oil companies are recommended, such as:

Anticorit 5 of Messrs FUCHS, D – 6600 Mannheim, Germany

Lubrication Oil MTL – L – 644 B of MOBIL-OIL

Shell ENSIS Fluid 2360 of SHELL

RUST BAN 395 of ESSO

It is also ESSENTIAL that the fuel system be drained.

Items (1) to (3) should be carried out every 90 days.

9.5.3 Returning to Service from Storage

- 1) Restore the engine to operation according to the Aircraft Manufacturers instructions.
- 2) If the aircraft been laid-up for more than 6 months, please carry out 9.5.2 ((1) to (6)).
- 3) Rotate the engine by hand several times to ensure that all excess oil is drained via the spark plug holes.
- 4) Clean and refit, or replace, the spark plugs.
- 5) Check the engine for external damage or deterioration suffered during storage, and rectify as necessary.
- 6) Clean engine to remove inhibitor and remove all storage blanks.
- 7) Refit engine in accordance with the aircraft manufacturer's instructions.

CAUTION !

Stale fuel must NOT be reused!

10.0 ENGINE EMERGENCY PROCEDURES

10.1 Fan Belt Failure

In the unlikely event of a fan belt failure, the indication will be a sudden rise in Rotor Cooling Air temperature. The engine load / RPM should be reduced as much as is practical to prevent further heat build up. If the rotor cooling outlet air temperature reaches 120 °C the engine should, if possible, be switched off. Continued running of the engine under these conditions will cause damage.

10.1.2 Charge Circuit Fail Alarm

In the unlikely event of a charging circuit failure, indicated by the appropriate alarm, the electrical bus bar will be fed automatically from the battery. Any non-essential electrical items should be switched off. The battery should be capable of providing sufficient power to run the CDI unit etc. for a minimum of ½ hour. Reducing power will not significantly increase engine-running time.

10.1.3 Low Oil in the Tank

In the unlikely event of low oil alarm the engine RPM should be reduced as much as is practical. Flying time should be limited to a total of 10 minutes at this reduced power. Flying under such conditions may cause damage to the engine.

10.1.4 Low Fuel Pressure

If low fuel pressure is indicated, the engine may stop or operate at reduced power and may also indicate an excessively high exhaust temperature. Throttle setting should be adjusted, if practical, to minimise excess temperature.

Continued operation at excess exhaust temperature will cause damage to the engine.

10.1.5 Rotor Cooling Air Temperature

If the rotor cooling air temperature rises above the specified limit, the engine should be shut down as soon as possible. Continued operation at excess temperature is likely to cause damage to the engine.

10.1.6 Water Temperature

If the water-cooling temperature rises above the specified limit, the engine should be shut down as soon as possible. Continued operation at excess temperature is likely to cause damage to the engine.

11.0 MAINTENANCE NOTES

11.1 Austro Engine GmbH Available Consumables

R1A-06-000-803	Rotor Cooling Air Filter
R1A-06-000-805	Induction Air Filter
Engine Oil	see Chapter 5.2.10
Glysantin Aluprotect Premium	Engine Coolant (One Litre Container)
Copper ease	Copper ease
Loctite 243	Screw locking
Loctite 595	Sealing silicone
R1A-09-000-801	Spark Plug (NGK)
K&N Filter Oil	Air Filter Oil
R1A-30-000-801	Injector

For further part replacement contact Austro Engine GmbH.

11.2 General Torque Settings

Bolts / Socket Head Cap Screw

4 mm	2.0 Newton Metres (Nm)
5 mm	4.5 Nm
6 mm	8.5 Nm
8 mm	21.5 Nm
10 mm	30.0 Nm

Nuts and Stiff Nuts – as above.

11.2.1 Specific Torque Settings

Spark Plug	10.0 Newton meters (Nm)
Coolant Temperature Sender	4.5 Nm
Starter Motor Terminal	8.0 Nm
Oil Pump Inlet Fitting	2.5 Nm (caution)
Oil Pump Outlet Banjo	2.5 Nm (caution)
Oil Pipe Nut & Olive	3.0 Nm (caution)

11.3 Checking & Setting Fan Belt Tension

FIG. 8

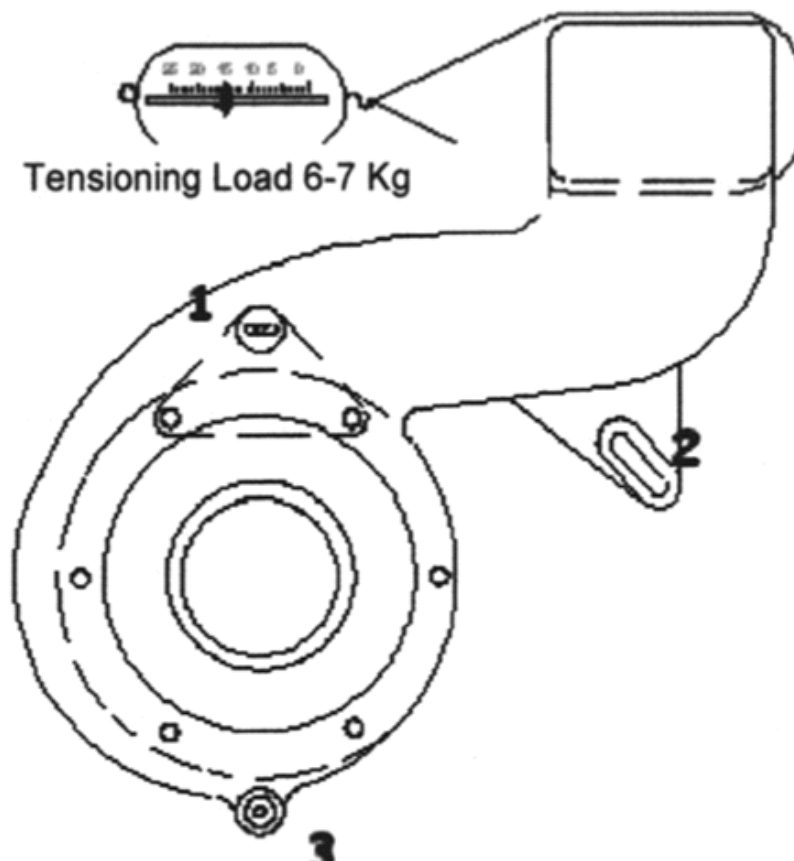

NOTE !

The silicon rubber tube and the tie wraps are left in place during the test.

- 1) Slacken the three attachments numbered 1, 2 and 3 above.
- 2) Attach a loop of suitable material around the fan outlet duct.
- 3) Using a suitable spring balance, apply a force to the loop of 6 – 7 Kilograms.
- 4) With this force still applied, tighten the 3 housing attachments.
- 5) Confirm the attachments are not at the end of their adjustment slots.
- 6) If a new belt is required, see Section 13.5.2

11.2.4 Adjusting engine idle speed

For adjusting procedure, and precautions, see the aircraft manufacturer's instructions.

12.0 SCHEDULED MAINTENANCE

12.1 Maintenance Schedule

ALL HOURS QUOTED ARE ENGINE HOURS

ITEM	1A	1B	2	3	4
a) Engine oil level / coolant level check	X	X	X	X	aircraft manual
b) Coolant leak check		X	X	X	13.4
c) Insp. / clean / replace air filters			X	X	13.5.4
d) Insp. engine, mountings and all external fasteners			X	X	aircraft manual
e) Check fan belt condition & tension			X	X	13.5.1
f) Check cooling system condition and security			X	X	13.0
g) Inspect / clean / replace spark plugs			X	X	14.1
h) Full engine ground run			X	X	15.0
i) End plates – examine seals & seal faces				X	14.0
j) Inspect fan impeller (300 hours)					13.5.5
k) Renew coolant, pressure test system (annual)					13.3
l) Replace fan belt (earlier of 300 hrs or 5 yearly)					13.5.2
m) Replace in line fuel filter				X	aircraft manual

1A = Check A (every flight)

1B = Check B (every flying day)

2 = every 50 hrs OR annually

3 = every 150 hrs or 3 yearly

4 = Section Reference

12.2 Typical 50 Hours Check

NOTE !

Visual Checks Only unless stated! All Checks to include Fastenings, Cracking, Leaks, Discoloration and Wire Locking!

REF	ITEM	CHECKS / COMMENTS
1	Water Outlet Cover	Leakage
2	Water Hoses	Security of all clips – leaks
3	Oil Separator	Leakage and temperature sensor connection
4	Oil Pump – Lines and Terminations	Leakage
5	Spark Plug Coils and Plug Caps	Cables and terminations
6	Spark Plug Condition	Connection & gap area
7	Engine Mounts – Starboard Side	Nuts, bolts secure
8	Starter Motor Mounts and Cable	Bolts and cable connections
9	Starter Pinion – Condition and Laxity	Teeth, free movement, play
10	Generator (Stator / Rotor)	Note any debris in the area

WARNING !

Ensure that all switches are OFF before rotating the engine.

11	Starter Ring – rotate Engine via Prop	Chipped or missing teeth
12	Generator Cables	Signs of contact and chafing/cracking
13	Lower Timing Sensor and Cables	Signs of contact and chafing/cracking
14	Water Pump Housing	Vent hole
15	Upper Timing Sensor and cables	Signs of contact and chafing/cracking
16	Fan Housing	Cracks
17	Fan Belt	Check tension and condition
18	Fan Filter – remove and check	View fan impeller – Debris – Cracks
19	Engine Mounts – port side	Nuts, bolts
20	Fuel Rail, Injector, Pressure Regulator	Leaks – Cracks – Cable Connection
21	Linkage, Throttle Stops	
22	Ram Pipe	Check temperature sensor connection
23	Induction Air Filter	Cleanliness and damage
24	Rotor Housing drain screw	Security – leaks
25	Exhaust System - complete	Overheat adjacent parts – security
26	Voltage Regulator and Cables	Signs of deterioration
27	CDI and Trigger Cables	Signs of deterioration

28	Engine Alarms, Transducers and Cables	Signs of deterioration
29	Oil Tank and Vent	Security – Leaks – Level - Connections
30	Radiator and Overflow Tank	Security – Damage – Leaks – Debris – Level
31	Oil Separator Hoses	Leakage
32	Rotate Propeller by Hand	Check 6 x Compression on prop

NOTE !

Carry out engine ground run according to check list!

12.3 Mandatory Life Limitation

There is no life limit of the engine, engine operation is on condition.

NOTE !

Reliable operation of this engine is dependent upon injector replacement in accordance with maintenance recommendations.

13.0 COOLING SYSTEM

13.1 Liquid Cooling System

Coolant Level Check: Refer to Aircraft Manufacturer's Instructions.

In a fault free system, the coolant level will not alter significantly. Any unusual drop in the coolant level in the tank indicates a fault in the system that must be rectified before further flights.

13.2 Coolant Hose Inspection

Check all hoses for cracks, wear, security and leaks (a white crust around a hose joint is an indication of a leak!). Refer also to engine installers handbook. If a leak is found, replace hose and hose clips, tighten hose – clips etc. as necessary and check / bleed / pressure test the system as detailed below:

13.3 Coolant System Filling and Bleeding

NOTE !

This test should be carried out if leaks are suspected after any part of the coolant system has been disturbed.

NOTE !

This is a guide, any variations in the aircraft manual should be followed!

- 1) Slowly fill the system with the coolant mix
- 2) Undo bleed plugs until fluid escapes, then tighten.
- 3) Top up radiator header tank with coolant mix.
- 4) Check for coolant leaks at all connections / interfaces.
If in doubt fit a coolant pressure tester
- 5) If required fit a coolant system pressure tester (Blue Point No STV 262 or similar) to the header tank and pressure test.
- 6) Recheck bleed points for air after the first engine run.
- 7) Repeat (6) until no further air is emitted from the bleed point(s). When running the engine ensure that coolant temperature rise is slow and consistent with warm up and no sudden temperature jumps occur. If the coolant temperature suddenly rises then there will still be entrained air in existence and the cycle must be repeated.
- 8) Top up header tank with coolant mix. Refit the filler cap and wire lock if appropriate.
- 9) Fill the overflow tank with coolant mixture within the MINIMUM and MAXIMUM levels.
- 10) Carry out full engine ground run.

CAUTION !

If coolant temperature rises rapidly shut down the engine and bleed the system again!

WARNING !

Risk of scalding – do not remove the pressure cap from the radiator until the engine and radiator have cooled.

13.4 Coolant System Pressure Test

- 1) Remove header tank pressure cap and fit a Coolant System Tester (Blue Point No. SVT262 or equivalent) in its place.
- 2) Apply pressure of 17 p.s.i (1.2 bar) to the system.
- 3) This pressure is to be held for 5 minutes during which time it must not drop by more than 0.5 p.s.i (0.03 bar)
- 4) Whilst under pressure the coolant system should be checked visually for any leaks for weeps at all connections.

13.5 Air Cooling System

13.5.1 Fan Belt

Check fan belt condition. Examine belt for fraying, cracks or broken strands. If in doubt replace it. Check belt tension as in 11.3. Adjust as necessary.

NOTE !

Need for significant or regular adjustment indicates need for belt replacement! When changing a fan belt, see 11.2 for torque settings!

13.5.2 Fan Belt Replacement

- 1) Drain off the coolant & remove connections to the water pump.
- 2) Disconnect alternator leads and oil pipes.
- 3) Remove the fan assembly and check bearings for play / roughness.
- 4) Remove the water pump housing along with the alternator stator assembly and check the water pump bearings for play.

NOTE !

Care should be taken in withdrawing the assemblies due to the loose internal tufnol drive coupling!

- 5) Fit the new Fan Belt (using Austro Engine GmbH "Fan Belt Kit").
- 6) Reassemble using the reverse procedure for items (2) to (5) inclusive, above, and tension the belt as in 11.3 Fig. 8

NOTE !

Replace tufnol drive coupling from the fan belt kit and assemble with the reduced diameter towards the water pump!

Fit the new O-Rings in the water pump housing with those from the fan belt kit using compatible grease to hold in place!

Use Loctite 242 on all fixings!

IF IN DOUBT PLEASE CONTACT Austro Engine GmbH!

- 7) Connect services, as appropriate and fill with coolant.
- 8) Ensure that the coolant lines and oil lines are bled.
- 9) If necessary, pressure test the coolant system as per aircraft manual or chapter above, and check for leaks.
- 10) Test run the engine to verify satisfactory operation before flight.

13.5.3 Air Filters

The two air filters, induction and rotor cooling air, should be visually inspected at the specified intervals for contamination, large pieces of debris and cracks. Both filters may be cleaned and re-used, although great care must be taken to correctly follow the manufacturer's instructions. Damaged filters should be replaced.

13.5.4 Air Filter Cleaning Procedure:

- 1) Tap filter gently, and then brush outside of filter with a soft bristle brush, to remove loose dirt.
- 2) Wash the outside of the filter with mild liquid soap and warm (maximum 40°C) water, by agitating the filter in the solution.
- 3) Ensure that the contaminated solution does not come in contact with the inside surfaced of the filter.
- 4) Rinse off the filter, from the inside, with clean low pressure water – from a tap or a similar supply. Rinse thoroughly to ensure all soap is removed.
- 5) Examine filter and if necessary repeat stages 2 and 3.
- 6) Shake off all surplus water and allow filter to dry naturally.
- 7) Re-oil element:
Aerosol – Spray one pass per pleat into each pleat, from the outside
Liquid – One bead of oil every 6 mm down each pleat.
- 8) Check that no white patches remain after 10 minutes.
- 9) Re-oil where necessary. A red dye in the oil clearly shows those areas that have been correctly oiled.
- 10) Reinstall air filter and tighten all clips and fittings.

NOTE !

Do not use harsh detergents, caustic solutions, solvents, fuel, steam, or pressure washers!

CAUTION !

Excess heat (over 40°C), or compressed air will damage the filter:

Do not use without re – oiling!

Only use filter oil from Austro Engine GmbH or K & N!

CAUTION !

Once the filters have been removed, the associated duct and fan impeller should be inspected for dust or debris of any type. If found, it indicates inadequate filter care or a damaged filter and could have serious consequences.

Advice should be sought from Austro Engine GmbH on the significance of this material and the effect it may have on the engine. Either or both filters should be replaced if their condition is suspect.

13.5.5 Rotor Cooling Air Fan Impeller

- 1) At the intervals stated in 12.1 the fan impeller should be inspected. The complete fan should be removed from the engine and the bearing housing assembly removed from the fan housing.
- 2) Carefully examine the impeller for cracks with a X 10 magnifying glass, particularly on the fan blade – back plate, root radius. No cracks are allowed.

NOTE !

If in doubt change the impeller / bearing housing assembly!

The impeller cannot be removed from spindle!

- 3) Refit and check the fan belt tension (see section 11.3).

14.0 ENGINE INTERNAL INSPECTION

Remove all dirt from the exterior of the engine and inspect for evidence of overheating or other unsatisfactory conditions.

Inspect rotor tip seals and internal side plate faces.

- 1) It will be necessary to remove the throttle body and the exhaust pip to carry out this inspection. The use of a 'Boroscope' or fibre optic probe facilitates viewing.

NOTE !

Care must be taken to ensure the probe is withdrawn before the engine is rotated!

- 2) Once the openings are exposed, rotate the eccentric shaft by hand to view the rotor tip seals. Each seal should not be stuck in the groove and free to spring. The side plate seal faces inside the engine should not exhibit significant distress. Minor scoring and scuffing is acceptable. It is important to obtain a good view of the side faces above the centre line of the engine, where the cooling medium is air. This can only be achieved through the inlet port.
- 3) If there is any doubt about the acceptability of the faces or the seals, then access should be gained to the air outlet of the front plate by removal of the oil separator. If there are any hard carbon deposits on the internal walls of the duct in the front plate then the side seals may have allowed combustion gas to blow by. Austro Engine GmbH should be consulted if this condition is found.

14.1 Spark Plug

The spark plug is of the surface discharge type with a long life platinum centre electrode. See 11.1 for the replacement Part Number.

The spark plugs must be removed for inspection at the intervals required in the maintenance schedule.

- 1) Check the electrical connections for corrosion and lightly smear with silicone grease.
- 2) Clean the electrode area of the plugs with gasoline if required.
- 3) If possible check plug function under pressure.
- 4) Replace spark plug in engine, (torque to value as in 11.2.1).
- 5) Anti-seize grease must be used on the threads. See 11.1 for Part Number.

CAUTION !

Fitting other types of spark plug may cause damage to the engine!

NOTE !

Do not sand blast, or clean with steel or brass wire brush, or use abrasive materials!

If due to local conditions, the plug connections become corroded then the corrosion may be removed from the plug nipple with a wire brush and the inside of the plug cap cleaned with a dry cloth or paper wiper. When complete, re-smear the connections with fresh silicone grease. Torque to the value given in 11.2.1. If the plug are unserviceable they should be replaced with new ones.

15.0 GROUND RUN

15.1 Pre-start Checks Outside Aircraft

- 1) Position aircraft into wind
- 2) Brakes fully on and wheels chocked
- 3) Check fuel drains, (no water)
- 4) Check coolant level at overflow tank
- 5) Check oil tank level
- 6) Check fuel level

15.2 Pre – start Checks Inside Aircraft

- 1) Close and lock canopy if appropriate
- 2) Record outside air temperature (minimum limit -10 °C for normal starts)
- 3) Battery Master ON
- 4) Check / note all indicators and alarms, as indicated in the aircraft manufacturers manual
- 5) Record fuel gauge reading
- 6) Check both ignitions ON
- 7) Check fuel pump ON
- 8) Alternator Master ON
- 9) Avionics off

15.3 Ground Run

Start the engine (see also 9.1). When the coolant temperature has reached 50 °C, carry out and record the following ground run checks.

15.4 Ground Run Check List (example)

ENGINE GROUND RUND RESULTS

Date:..... A/C Reg..... Engine No.....
 Flight Hours..... Total Running Time (hrs meter).....
 QFE..... Outside Air Temperature.....

Instrumentation – Gauge / Alarm Function Test

Pressure	Temperature	Others
	RCAO	Battery Fail Alarm
Low Fuel Pressure Alarm	Engine Coolant	Charge System Fail Alarm
	OAT	Flytronic Error Warning
	EGT 1 (optional)	Fuel Flow
		Oil Low Alarm

Record data after 1 minute steady running at each condition after warm – up

	Engine RPM	Coolant Temp	RCAO Temp	Remarks
Warm – up
Idle
5000
6000
Max
Idle

Mag Drops at 6000 RPM Ign. 1 Ign. 2
 Acceleration tests (3 off) Remarks
 (Idle to Max RPM response)
 (1 sec throttle time)

Comments If any adjustments are made as a result of this ground run they should be recorded and the ground run repeated

.....

Record results in engine maintenance file !

16.0 MAINTENANCE AND OVERHAUL

For maintenance of particular system or for overhauling the engine please contact Austro Engine GmbH or engine installer.

17.0 TROUBLE SHOOTING

17.1 General

NOTE !

This section is included as an aid although some items may be carried out by the owner / pilot, most would be carried out by a maintenance organisation.

NOTE !

Replace alls gaskets, seals and joint material if disturbed!
Coolant, fuel & oil systems **MUST** be bled if disturbed!

CAUTION !

If, during troubleshooting, any foreign object fall into the engine internals, through the spark plug holes, the inlet or exhaust ports, or the rotor air cooling inlet and exit passages, they must be removed before attempting to turn or run the engine!
Failure to do so may result in considerable damage to the engine!

WARNING !

Do not stand within the area of the propeller **AT ANY TIME**, unless it is essential and you have confirmed that both ignition switches are 'OFF'!

17.2 Rough Idle

- | | | |
|------------------|---|--|
| Ignition failure | - | Check continuity of wiring and connectors. |
| | - | Check spark plugs. |
| | - | Check CDI Unit |

17.3 Engine Misfires on One Spark Plug

Dirty plug cap / terminal	-	Clean / replace
Wiring fault	-	Wiring to earth or open circuit
Faulty spark plug	-	Clean / replace
HT fault	-	Check / replace spark plug / HT lead / plug cap for arcing
CDI Unit	-	Check operation

17.4 Engine Cannot Develop Full Power

Incomplete throttle opening	-	Adjust throttle linkage
HT fault	-	Check/ replace spark plug/ HT lead/ plug cap
Increase in exhaust back pressure	-	Investigate exhaust / replace
Loss of compression	-	Investigate
Blocked induction filter	-	Replace / clean filter
Low fuel pressure	-	Investigate fuel system / replace fuel filter

17.5 Excessive Rotor Cooling Outlet Temperatures

Excessive back pressure in outlet duct	-	Rectify before continuing running engine
Blocked rotor air inlet filter	-	Clean or replace filter
Slipping / broken fan belt	-	Adjust / replace
Fan failure / impeller failure bearing failure	-	Replace assembly
Stuck side seal(s)	-	Investigate outlet for black carbon deposits

If found please contact Austro Engine GmbH.

Investigate possible exhaust leakage within the engine bay area.

17.6 Liquid Coolant Overheats on Medium and High Power

Restricted radiator core	-	Rectify
Constricted radiator hose	-	Rectify
Water pump drive failure	-	Overhaul pump
Air in system	-	Vent / Bleed
Coolant leak	-	Rectify

18.0 NOTES FOR INSTALLERS OF ENGINES

Section		Page
18.1	General Notes	41
18.2	Engine Overall Dimensions	42
18.3	Cooling System	43
18.4	Fuel System	46
18.5	Procedure for Setting Carburettor	47
18.6	Oil System	49
18.7	Electrical System	50
18.8	Ignitions System	54
18.9	Engine Mounting	57
18.10	Exhaust System	57
18.11	Air Filters	57
18.12	Drive Interface	57

18.1 General Notes

NOTE !

In order to maintain the warranty, use only genuine Austro Engine GmbH parts.

Use only clean screws and nuts and always check threads for damage. If in doubt, always renew them.

Once loosened, always renew 'stiff' nuts, i.e. self-locking nuts.

Always use the specified torque values.

Whenever components are disturbed, always renew gaskets, seals, jointing material, O-rings and sealant

NOTE !

Do not use additives with the oils.

Copper slip anti-seize must be used on spark plug and exhaust flange nuts.

It is **VITAL** that all coolant and oil systems are bled before attempting to operate the engine for the first time, or if they are subsequently disturbed in any way.

18.2 Engine Overall Dimensions

FIG 9

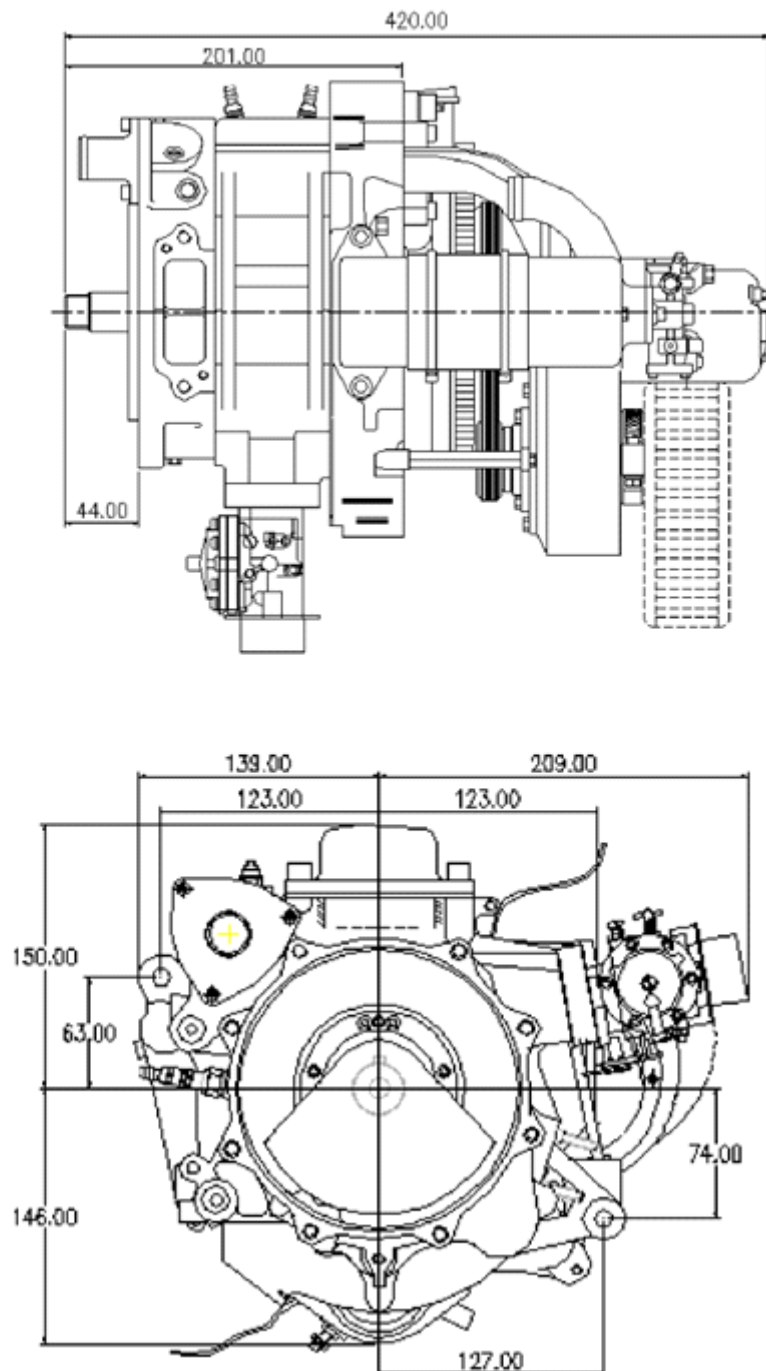

18.3 Cooling System

18.3.1 General

Arrangement must be made by the engine installer to carry the rotor cooling air out from the front plate elbow, if fitted, to the oil separator or to some suitable mean of the removing the oil entrained in the cooling air before allowing it to vent overboard.

Cooling air should be arranged to flow over the engine and exhaust system whenever the engine is in operation.

An ample supply of cold air must be available to the induction air and rotor cooling fan filters whenever the engine is in operation.

CAUTION !

On no account should this rotor cooling air be used directly for cabin heating it may contain products of combustion including CO & CO₂

On no account should the engine be run without either of the air intake filters in place.

A VDO temperature sensor is fitted to the engine in the front end plate. Provision of a compatible gauge is the responsibility of the engine installer.

Coolant 50/50 water/ethylene glycol mix (A corrosion inhibiting anti-freeze must be used, refer to 5.2.6). This water/glycol mix will provide protection down to -36 °C.

Operating temperature is in the range of 60 °C to 90 °C after warm up. Maximum continuous 100 °C.

Heat rejection rate approximately 25 kW of heat is rejected to the coolant when the engine is operated at max continuous power (50 BHP).

An integral water pump is provided with the engine. This provides a water flow of approx. 40 liters per minute at 7000 RPM.

CAUTION !

Radiator. The optimum radiator design will vary with each installation. It is the responsibility of the installer to provide an adequate cooling system and thus ensure that the maximum recommended coolant temperature is never exceeded even under the most adverse operation conditions. The design should also ensure that the minimum operating temperature can be achieved under all flying weather conditions.

Flight trials will probably be necessary to confirm that the design caters for the above conditions.

18.3.2 Suggested pipe bore

Outlet from engine and return from radiator 25-28 mm.

Header tank to radiator 5 mm minimum.

18.3.3 Max burst pressure

45 psi at 150 °C

Expansion tank at the highest point

Positive head at pump entry is necessary to ensure zero cavitation

Air volume in expansion tank should allow

- 1) Rapid pressure rise is possible as coolant warm up
- 2) No coolant is ejected during / after boil

18.3.4 Cooling Circuit Schematic

Typical Cooling Circuit

Fig. 10

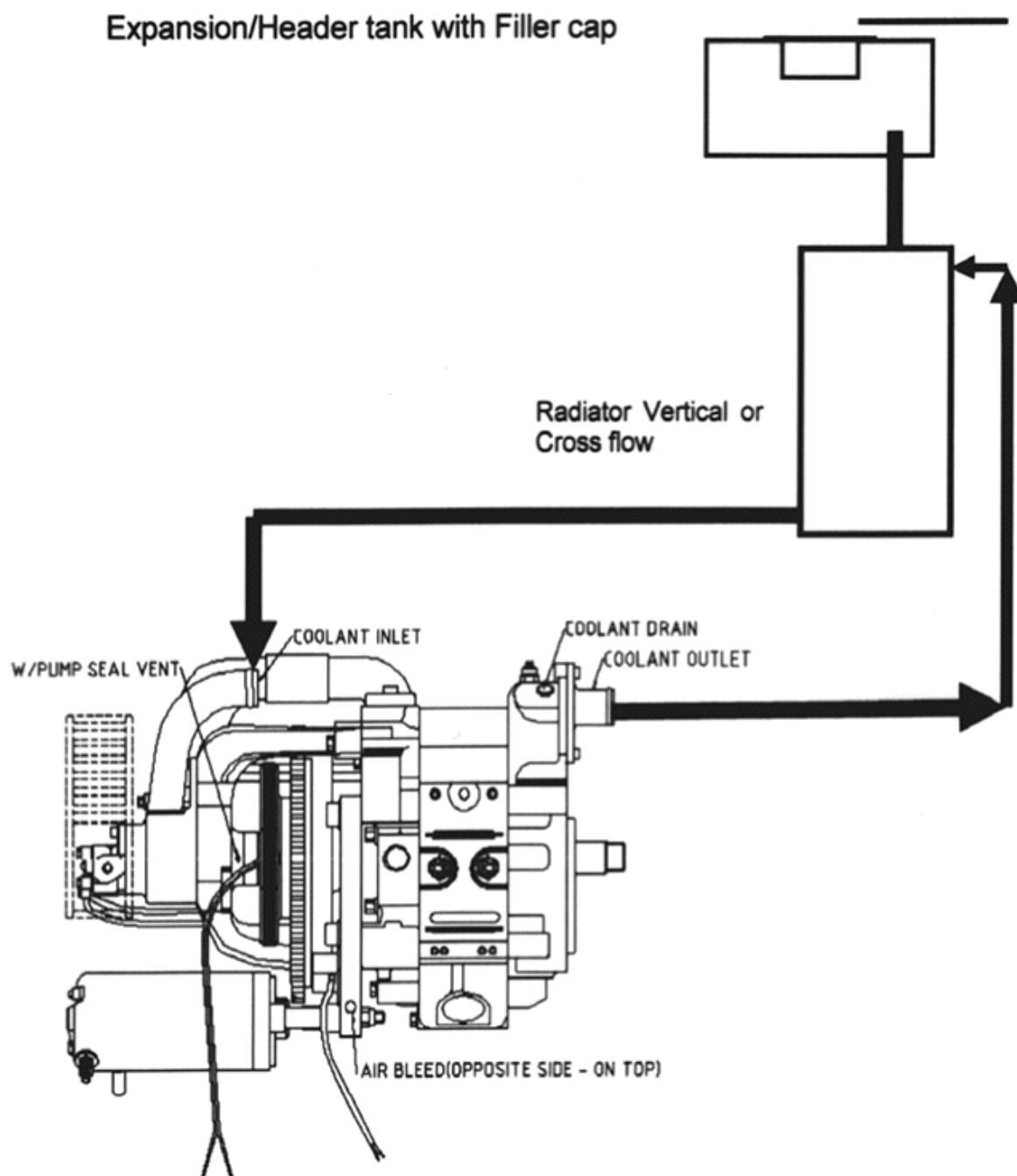

18.3.5 Temperature Sensor

Air Temperature sensor

Supplied by Austro Engine GmbH and should be installed with its probe in the induction airflow.

Rotor cooling air out temperature sensor

Supplied by Austro Engine GmbH and should be mounted in the rotor cooling air flow within 100mm or less downstream from outlet.

18.4 Fuel System

18.4.1 Fuel Specification

Refer to chapter 5.2.7

18.4.2 Fuel delivery

No fuel pumps are provided by Austro Engine GmbH. Therefore electric pumps each capable of delivering 45 liters an hour at working pressure.

18.4.3 Fuel filters

No fuel filters are provided by Austro Engine GmbH. Therefore a filter of 40 microns or better with a flow capacity of least 50 liters per hour at 0.1 bar pressure drop must be fitted in the fuel delivery line after the pumps.

18.4.4 Pressure Regulator

No fuel pressure regulator is supplied with this engine. It is the responsibility of the aircraft manufacturer / installer to provide the engine with fuel regulated at working pressure.

18.4.5 Water in Fuel

The fuel system shall incorporate suitable means of isolating, removing, and checking for the presence of water in the fuel system before each flight.

18.4.6 Fuel Lines

Fuel lines must be routed away and protected from hot engine and exhaust components. Fuel line should be of sufficient quality and appropriate to the pressures transmitted. Fuel hose end connections must be of threaded taper seat type and should be permanently swaged to the hoses. Push-on type hose connections are not acceptable fuel systems.

NOTE !

The whole fuel system must be able to allow a minimum fuel flow rate of 45 liters per hour.

18.5 Procedure for Setting Carburettor

The following parameters will effect the required carburettor settings for correct and optimum engine operation:

Engine fuel supply pressure	The fuel pressure should be 5 ± 1 psi static
Carburettor Air Filter	If an air filter other than that supplied is fitted this may effect the mixture screw settings. There should not be a pressure drop across the filter of more than 1" Water Gauge at 7000 RPM (approx. 70 cfm airflow).
Ram Pipe length	This should be 14.5 inches. Variations will seriously effect engine performance.

18.5.1 Basic Settings

The following sequence of action should now be followed:

Set carburettor fuel control needle to basic setting as follows:

High Speed settings	H Screw 1 3/8 turns out
Low Speed settings	L Screw 3/4 turns out
Idle stop	2 turns in from just moving the throttle valve

Start the engine

Turn fuel supply on

Turn ignition switch on

Operate the primer to the manufacturer's instruction before cranking engine

Set throttle 10% open position during engine cranking

WARNING !

Ensure all personnel are clear of propeller and aware that the engine is to be started.

NOTE !

Choking the carburettor by covering the carburettor inlet will not enrich the fuel supply, due to internal venting of the dry side of the fuel-metering diaphragm to the carburettor mouth.

Engage the starter

If the engine does not start immediately, the throttle should be opened to WOT and slowly closed whilst cranking the engine. If the engine does not start within three attempts, there is probably a fault and this should be investigated.

Warming up

Having started the engine allow it to warm through at approx. 4000 rpm for 3-4 minutes, or until the engine reaches operating temperature (60 °C).

18.5.2 Setting the 'L' screw system

Return the throttle to idle. The low speed system is set by weakening the mixture (screwing the L screw clockwise) until the engine just begins to falter. Then increase the flow (turn anticlockwise) by the minimum amount to just achieve smooth running.

The Settings can be expected to be within $\pm 1/8$ of the original settings.

The aircraft manufacturer's required idle speed should then be set with the engine warm. If one has not been supplied then Austro Engine GmbH recommend 2250 rpm (with a minimum of 1750 rpm) if necessary, adjust the idle stop screw to achieve the appropriate speed.

If significant adjustment is required then also re-check the low speed (L) settings at this corrected idle speed.

18.5.3 Setting the 'H' Screw

Slowly increase the throttle to the WOT position. The maximum engine speed should be as stated in the aircraft manufacturer's handbook.

If no flowmeters are fitted, reduce the fuel flow from the high-speed system until the engine just begins to falter. Then increase the fuel flow until maximum engine rpm is just achieved.

The 'H' screw should be as weak (turned clockwise) as it can reasonably be, consistent with maximum engine rpm being achieved.

The maximum adjustment required is normally $\pm 1/8$ turn from the initial basic setting.

Return to idle and repeat section 18.5.2 to recheck the low speed setting.

Check the snap throttle response by moving the throttle from the idle to WOT in approx. 1 second. If the engine exhibits unacceptable hesitation, the low speed systems should be richened very slightly. Any such adjustment can be expected to be less than 1/16 turn.

18.6 Oil System

18.6.1 Oil tank

Oil tank is supplied by the aircraft manufacturer but must have a minimum usable capacity of 500 ml for each hour of engine running with a strainer of mesh size not larger than 0.5 mm.

18.6.2 Oil Separator

An oil separator may be fitted to remove oil from the rotor cooling air after it has passed through the engine. The recovered oil is returned to the induction system, this provides additional lubrication for the rotor seals, and is then burned in the combustion chamber. The cleaned rotor cooling air cools the exhaust system.

18.6.3 Line connections

The oil connection line between the tank and the pump should be calculated to provide AT THE PUMP INLET a minimum flow of 8 ml per minute at -10 °C by gravity.

18.6.4 Flow rate

The flow rate of the pump is pre-set and will not require adjustment.

18.7 Electrical System

The installation of the electric system and the Flytronic Engine Management System should be done in accordance with Austro Engine GmbH drawings. Please contact Austro Engine GmbH therefore.

No electrical circuit protection is provided by Austro Engine GmbH.

Voltage regulator connections are shown in wiring diagram. Fig. 11. Its temperature operation range is -30 °C to +65 °C (outer surface). Adequate cooling should be provided.

18.7.1 Voltage regulator wiring

Fig 11

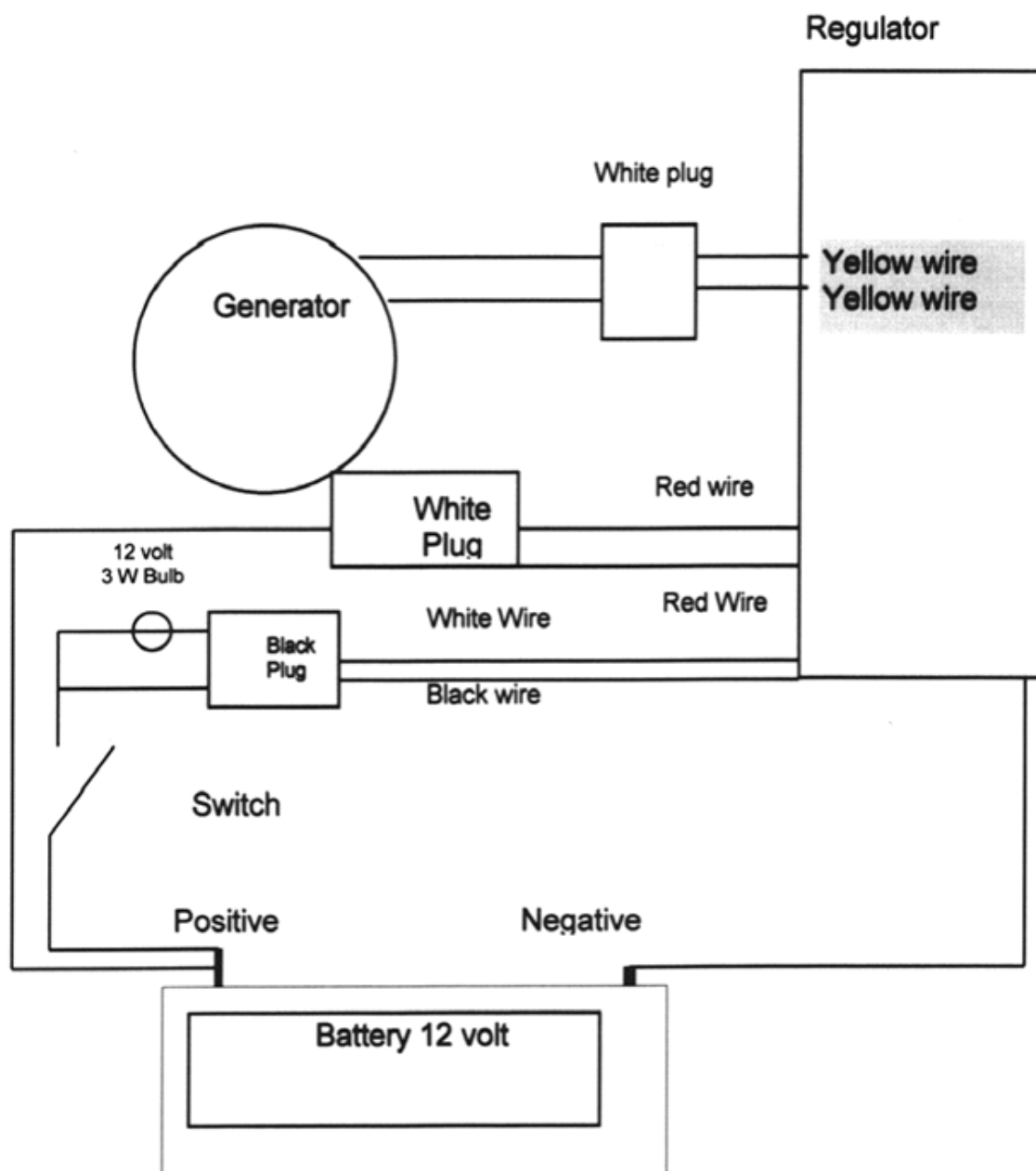

NOTE !

Circuit diagram refers to Austro Engine GmbH (part number E_R2 B 014) plug type CDI boxes. Coil wires at terminal C ignition box 1 and coil wire B at ignition box 2 have no connection.

18.7.2 Suggested Circuit Protection (Two wire alternator)

Fig 12

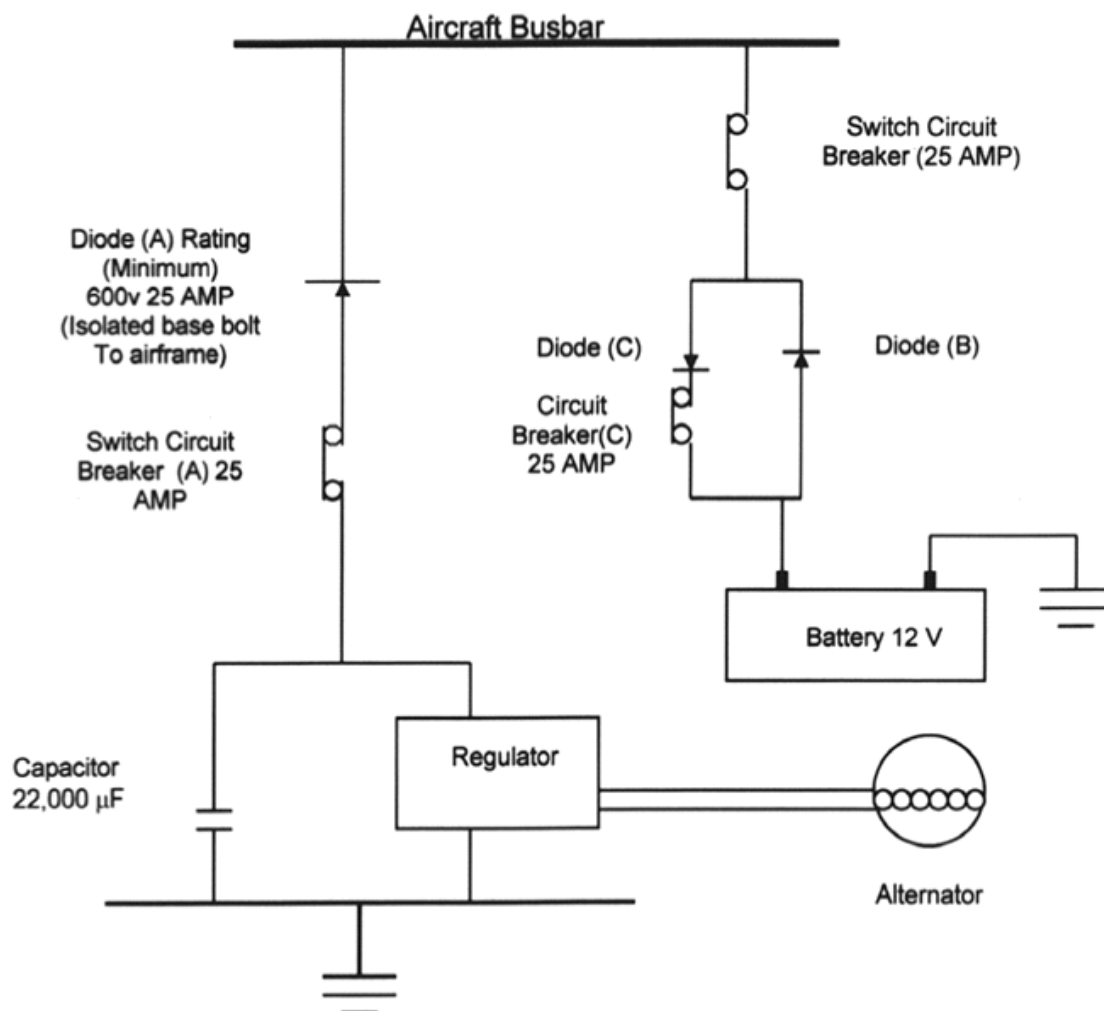
**NOTE !**

Austro Engine GmbH provide NO circuit protection.

Diode A protects bus bar from short in the generator side.

Breaker A is isolator for generator and protects bus bar from regulator failure.

Line from battery to bus bar is double insulated.

Breaker C allows battery charge but trips if battery short circuit.

Diodes should be on insulated heat sinks.

Engine will run with either battery or generator inoperative.

CAUTION !

Capacitor 22,000 μ F must be fitted. Failure to fit will result in damage.

NOTE !

Temperature limits -30 °C to +65 °C (outer surface) and adequate cooling must be arranged.

18.8. Ignition

18.8.1 CDI units Part Number E_R2 B 014

Fig 13

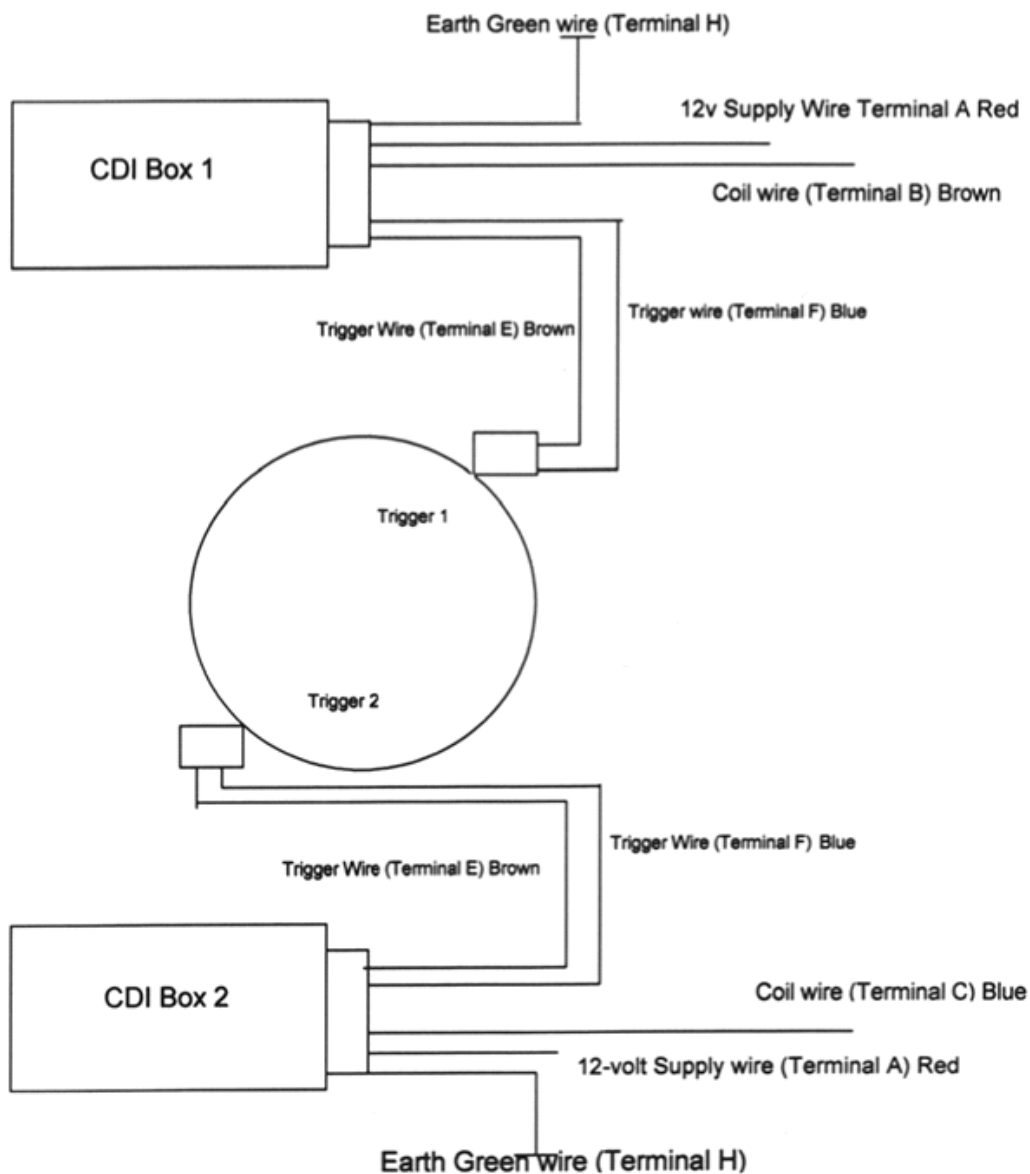

NOTE !

Circuit Diagram refers to Austro Engine GmbH part number R1B006/R1B007 flying lead type CDI boxes.

Coil wires at terminal C ignition box 1 and coil wire B at ignition box 2 have no connection.

18.8.2 Connection Plug Wiring

Ignition CDI control E_R2 B 014 connection plug wiring

Fig. 14

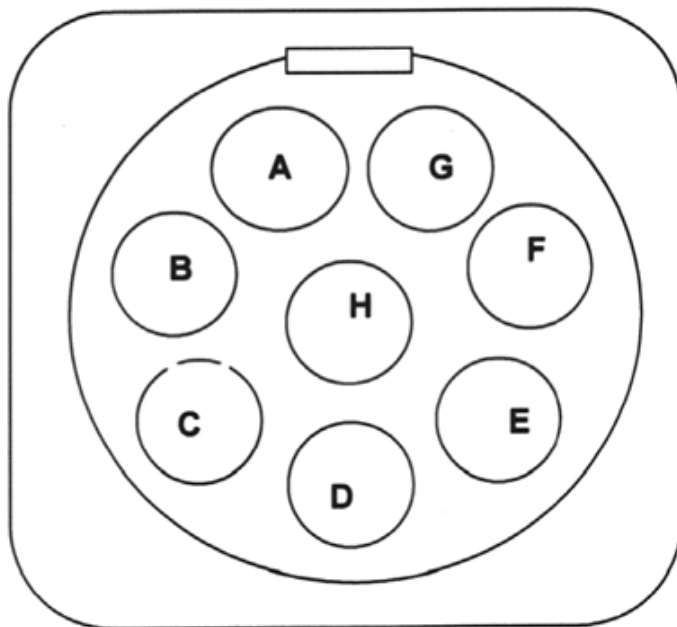

End View of
CDI box socket

A	B	C	D	E	F	G	H
+ 12 V	Output # 1 Brown	Output # 2 Blue	Trigger Screen Out	Trigger Signal + VE	Trigger Return - VE	Trigger Screen In	DC Ground

Terminal G and D are linked and have no connection to the PCB

18.8.3 Ignition CDI Part No R1 B 006 / R1 B 007

Fig. 15

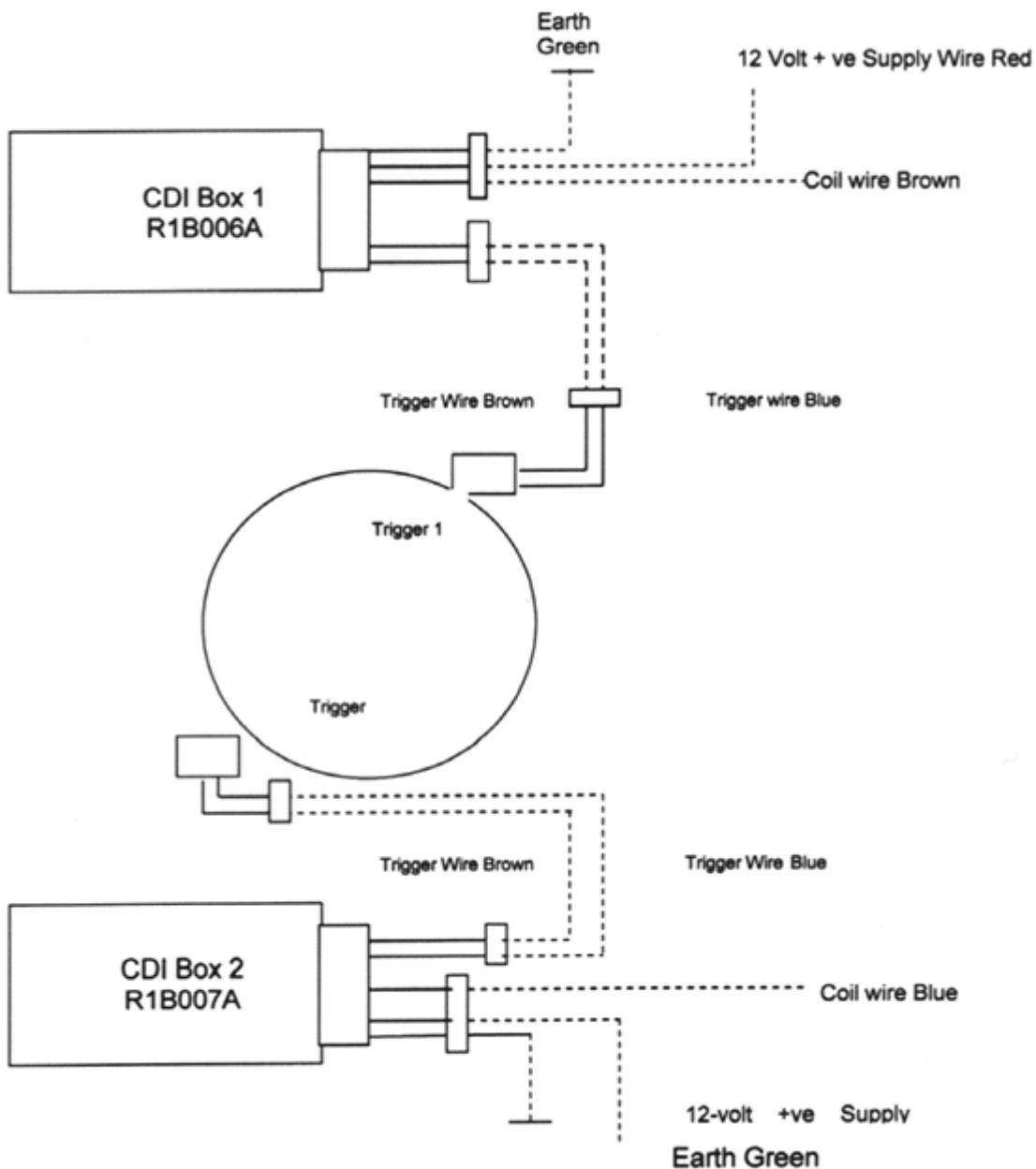

Circuit Diagram refers to Austro Engine GmbH Part No R1 B 006 / R1 B 007 flying lead boxes.

18.9 Engine mounting

The engine mounting points on the engine have been designed and tested to meet the required 15 g load test. Engine location and fitting remain the responsibility of the aircraft manufacturer. Contact Austro Engine GmbH for installation details.

18.10 Exhaust system

Exhaust design and fitting remains the responsibility of the aircraft manufacturer / engine installer. Limitations must be regarded.

18.11 Air Filters

Supplied by Austro Engine GmbH as part of design. For other air filters Austro Engine GmbH must be consulted.

18.12 Drive interface

The output shaft is parallel, fitted with a woodruff key for load transmission. For more details contact Austro Engine GmbH.

19.0 FORM SHEETS

19.1 Notification of Receipt

Austro Engine GmbH

Rudolf -Diesel – Straße 11
A – 2700 Wiener Neustadt
Austria

Tel: +43 – 2622 – 23 000
Fax: +43 – 2622 – 23 000
Internet: www.austroengine.at

Engine Manual AE50R – AB

NOTIFICATION OF RECEIPT

Copy Number:.....

Signature:.....

Date:.....

Name:.....

On behalf of:.....

Address:.....

.....

Austro Engine GmbH

Rudolf - Diesel – Straße 11
A – 2700 Wiener Neustadt
Austria

Tel: +43 – 2622 – 23000
Fax: +43 – 2622 – 23000 2711
Internet: www.austroengine.at

Engine Manual AE50R – AB

NOTIFICATION OF RECEIPT

Copy Number:.....

Signature:.....

Date:.....

Name:.....

On behalf of:.....

Address:.....

.....

19.2 Problem Report

Austro Engine GmbH

Rudolf – Diesel – Straße 11
A – 2700 Wiener Neustadt
Austria

Tel: +43 – 2622 – 23000
Fax: +43 – 2622 – 23000 2711
Internet: www.austroengine.at

PROBLEM REPORT

Date:	Engine No
Description :	
	Hours Run

For completion by **Austro Engine Staff Only**

Problem Report No	W.O.C. No
Action Taken :	Test Proc. No